

По вопросам продаж и поддержки обращайтесь:

Архангельск (8182)63-90-72
Астана (7172)727-132
Белгород (4722)40-23-64
Брянск (4832)59-03-52
Владивосток (423)249-28-31
Волгоград (844)278-03-48
Вологда (8172)26-41-59
Воронеж (473)204-51-73
Екатеринбург (343)384-55-89
Иваново (4932)77-34-06
Ижевск (3412)26-03-58
Казань (843)206-01-48
Калининград (4012)72-03-81
Калуга (4842)92-23-67
Кемерово (3842)65-04-62
Киров (8332)68-02-04

Краснодар (861)203-40-90
Красноярск (391)204-63-61
Курск (4712)77-13-04
Липецк (4742)52-20-81
Магнитогорск (3519)55-03-13
Москва (495)268-04-70
Мурманск (8152)59-64-93
Набережные Челны (8552)20-53-41
Нижний Новгород (831)429-08-12
Новокузнецк (3843)20-46-81
Новосибирск (383)227-86-73
Орел (4862)44-53-42
Оренбург (3532)37-68-04
Пенза (8412)22-31-16
Пермь (342)205-81-47
Ростов-на-Дону (863)308-18-15

Рязань (4912)46-61-64
Самара (846)206-03-16
Санкт-Петербург (812)309-46-40
Саратов (845)249-38-78
Смоленск (4812)29-41-54
Сочи (862)225-72-31
Ставрополь (8652)20-65-13
Тверь (4822)63-31-35
Томск (3822)98-41-53
Тула (4872)74-02-29
Тюмень (3452)66-21-18
Ульяновск (8422)24-23-59
Уфа (347)229-48-12
Челябинск (351)202-03-61
Череповец (8202)49-02-64
Ярославль (4852)69-52-93

Единый адрес: frn@nt-rt.ru Веб-сайт: www.fafnir.nt-rt.ru

Техническое описание системы измерения массы и уровня сжиженного углеводородного газа VISY-Stick LPG FAFNIR

VISY-Stick LPG

VISY-X tank gauging system
for LPG applications



Existing ATG systems may be integrated into the FAFNIR VISY-X system at any time.

Function description

The VISY-Stick LPG (Liquefied Petroleum Gas) level sensor supplies information about the fuel level in LPG tanks. The magnetostrictive sensor with buna float and pressure-resistant stainless-steel screw connection is specially designed for use in liquefied petroleum gas.

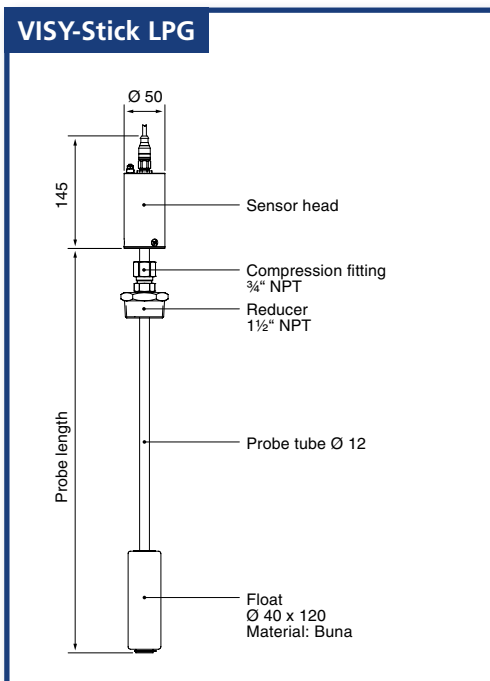

Approvals: ATEX, NEPSI, IECEx, UL-Brazil

Benefits of FAFNIR technology

- Magnetostrictive sensor for use in liquefied petroleum gas
- Sensor material: stainless steel
- Continuous detection of product level and product temperature
- Direct installation or installation with installation kit

LPG installation kit

For LPG applications



LPG installation kit for installing VISY-Stick LPG or TORRIX LPG

Function description

The optional LPG installation kit comprises a jacketed pipe with flange and a buna float. After the LPG installation kit has been installed in the fuel tank, the tank content sensor is inserted into the jacketed pipe without a float and screwed into position. The sensor is located outside the pressurised zone of the tank. This makes it possible to replace the sensor at any time without opening the tank.

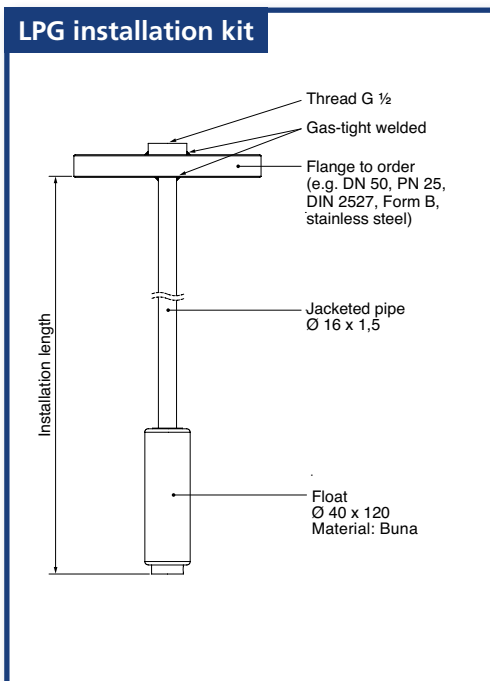

Benefits of FAFNIR technology

- Possible to replace a sensor without draining the tank first
- Cost savings, easy to install, maintenance-free

LPG installation kit adjustable



Adjustable LPG installation kit for installing VISY-Stick LPG or TORRIX LPG

Function description

The adjustable LPG installation kit comprises a jacketed pipe of variable installation length, which is secured in position by a compression fitting. With this installation kit, no prior knowledge of the exact installation dimensions is needed for the installation of the jacketed pipe. The length of the jacketed pipe can be shortened on-site. After the adjustable LPG installation kit has been installed in the fuel tank, the tank content sensor is inserted into the jacketed pipe without a float and screwed into position. The level sensor can be replaced at any time without having to depressurise the tank.

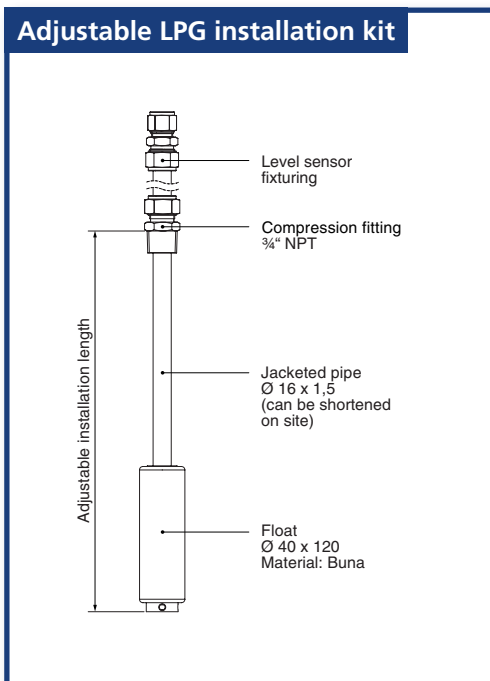

Benefits of FAFNIR technology

- Variable adjustment of installation length
- Possible to replace a sensor without draining the tank first
- Cost savings, easy to install, maintenance-free

TORRIX LPG



TORRIX LPG for direct connection inside the tank

TORRIX LPG (left), UM-X (right)

Function description

The TORRIX LPG level sensor for liquefied petroleum gas is designed to provide continuous gauging of fuel levels and is intended specifically for use in LPG tanks.

The magnetostrictive sensor with buna float measures the filling level and forwards this information to a control unit, such as UM-X.

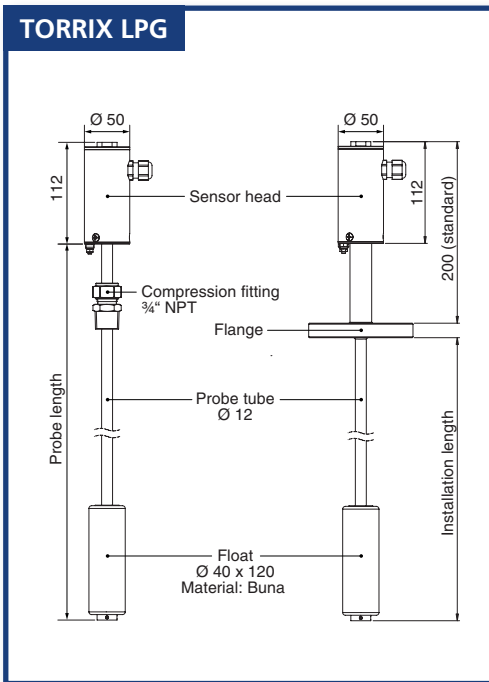

Approvals: ATEX, IECEx

Benefits of FAFNIR technology

- Magnetostrictive sensor for use in liquefied petroleum gas
- Sensor material: stainless steel
- Continuous detection of product level
- Direct installation or installation with installation kit

LS 300 / 500

For use in tanks and process containers



Due to the specially designed circuitry of the output contacts*, the transducer LS 500 LPG can be used as overfill prevention for LPG tanks.

Type LS 500 LPG (left), type LS 300 (right)

Function description

Overfill prevention devices are designed to prevent the overfilling of tanks and process containers. This safety device is an indispensable component for environmental protection when handling water pollutants. An overfill prevention device comprises a level sensor installed inside the tank and a transducer with alarm system and output terminal.

The LS 500 LPG transducer has been developed for use in conjunction with an LS 300 level sensor as an overfill prevention device for liquefied petroleum gas (LPG).

Two output relays are actuated independently in the redundant design of the electronics. An alarm must be triggered as soon as either one of the relays opens. Enablement must be achieved independently by both relay contacts (visual signal). Due to the special designed circuitry of the output contacts*, the transducer LS 500 LPG can be used as overfill prevention for LPG tanks and meets the requirements of VdTÜV code of practice, overfill prevention 100 – part 2; 12.2000.

* see Fig. 2: Connection assignment

Approvals: ATEX for Zone 0

Benefits of FAFNIR technology

- Proven millions of times under the most rigorous conditions
- Two-conductor connection to the transducer independent of polarity
- Continuous self-monitoring of the sensors

LS 300 / 500

Overfill prevention for Zone 0

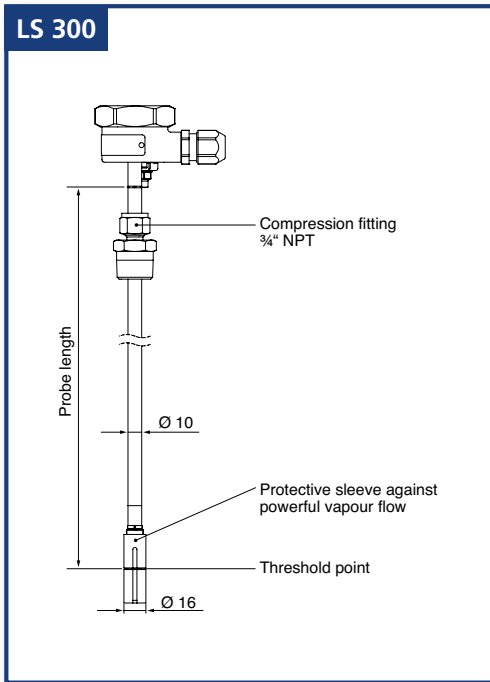

Fig. 1

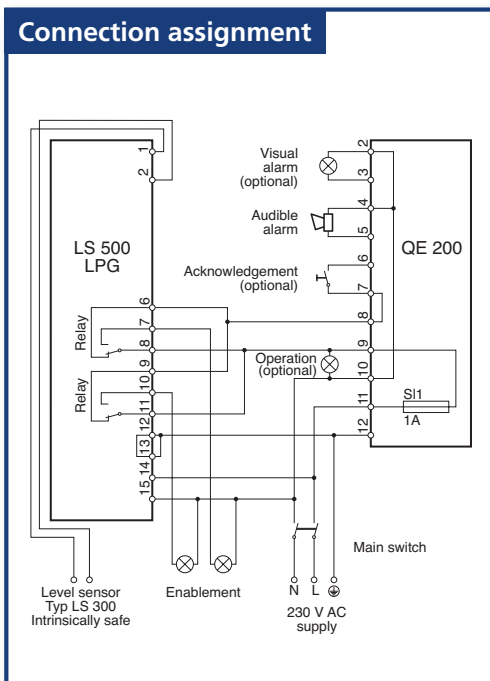

Fig. 2

Benefits of FAFNIR technology

- Compact, sturdy and corrosion-free design
- No on-site calibration required
- Absolutely maintenance-free

По вопросам продаж и поддержки обращайтесь:

Архангельск (8182)63-90-72
Астана (7172)727-132
Белгород (4722)40-23-64
Брянск (4832)59-03-52
Владивосток (423)249-28-31
Волгоград (844)278-03-48
Вологда (8172)26-41-59
Воронеж (473)204-51-73
Екатеринбург (343)384-55-89
Иваново (4932)77-34-06
Ижевск (3412)26-03-58
Казань (843)206-01-48
Калининград (4012)72-03-81
Калуга (4842)92-23-67
Кемерово (3842)65-04-62
Киров (8332)68-02-04

Краснодар (861)203-40-90
Красноярск (391)204-63-61
Курск (4712)77-13-04
Липецк (4742)52-20-81
Магнитогорск (3519)55-03-13
Москва (495)268-04-70
Мурманск (8152)59-64-93
Набережные Челны (8552)20-53-41
Нижний Новгород (831)429-08-12
Новокузнецк (3843)20-46-81
Новосибирск (383)227-86-73
Орел (4862)44-53-42
Оренбург (3532)37-68-04
Пенза (8412)22-31-16
Пермь (342)205-81-47
Ростов-на-Дону (863)308-18-15

Рязань (4912)46-61-64
Самара (846)206-03-16
Санкт-Петербург (812)309-46-40
Саратов (845)249-38-78
Смоленск (4812)29-41-54
Сочи (862)225-72-31
Ставрополь (8652)20-65-13
Тверь (4822)63-31-35
Томск (3822)98-41-53
Тула (4872)74-02-29
Тюмень (3452)66-21-18
Ульяновск (8422)24-23-59
Уфа (347)229-48-12
Челябинск (351)202-03-61
Череповец (8202)49-02-64
Ярославль (4852)69-52-93

Единый адрес: frn@nt-rt.ru Веб-сайт: www.fafnir.nt-rt.ru